

USER MANUAL

NARROW

SMART DOOR LOCK

OZ-FDL-33 LIFE STD 



Fingerprint



Password



OzoLife
Mobile App



RFID Card



Emergency
Key

DOWNLOAD NOW



OzoLife



OzoLife iOS



OzoLife Android

WWW.OZONESECUTECH.COM

EMAIL ID: INFO@OZONESECUTECH.COM | CUSTOMER CARE: +91-9310012300

INDEX

<u>Introduction</u>	1-2
<u>Lock Structure And Product Feature</u>	3
<u>Technical Specification</u>	4
<u>Installation Steps</u>	5-8
<u>Operation Steps</u>	9-14
<u>FAQ</u>	15
<u>Warranty Card</u>	16-17

INTRODUCTION

CAUTION

- Necessary safety measures must be ensured before starting the installation to prevent damage to assets and personnel.
- Accuracy of the door preparation is a critical parameter for the proper door installation, Lock functioning, and security of the product.
- Any deviation from the given specs and misalignments etc., can cause performance and security breaches.
- The product images shown in this document are for reference & representation purposes only & the actual product may differ from these.
- Check for leveling & alignment of doors before installation of the product.

The image contained in this manual is a reference used for description and instruction, and its types and colors may differ following the product model.

Safety cautions



Do not directly spray water when cleaning the product.

Water coming through into the product causes malfunction or abnormal operation.



Do not dismantle the product yourself. It may cause malfunction of product.

If you dismantle the product yourself, the product may not function as it should.



Do not place inflammable such as gas lighter near the product.

It may cause malfunction or abnormal operation.



Completely block holes on door after product installation.

There is a risk of intrusion through door holes.



Do not use the product at places exposed to water.

Since the product does not have water and dust proof structure, it may cause product malfunction due to short circuit.



Do not use the product in place with direct sunlight or high temperature.

It may cause malfunction or abnormal operation.



Do not install the product at place where water, snow or rain can come through.

It may cause malfunction or abnormal operation.



Do not impact on or alter the product.

It may cause malfunction or abnormal operation.



Replace all batteries with new one when changing batteries.

If old batteries are used with new ones, product life span cannot be guaranteed



Use alkaline battery only.

Using rechargeable battery may cause product malfunction.

Caution

Since the product is a keyless door lock, a part of the door lock may get damaged in case of malfunction. Therefore, the user needs to be familiar with the manual closing and opening of the device in an emergency.

1. Voltage: DC6V
2. Be cautious that reverse installation of batteries may cause liquid leakage or a burst.
3. When the battery is discharged, replace all batteries and DO NOT use used batteries with a new one.
4. Sensor operation temperature: 60°C (+10°C).

INTRODUCTION

CAUTION

Special Note Before Installation

- Necessary safety measures must be ensured before starting the installation to prevent damage to assets and personnel.
- Accuracy of the door preparation is a critical parameter for the proper door installation, Lock functioning, and security of the product.
- Any deviation from the given specs and misalignments etc., can cause performance and security breaches.
- The product images shown in this document are for reference & representation purposes only & the actual product may differ from these.
- Check for leveling & alignment of doors before installation of the product.

Do's

- Admin/Master should always be used by the primary owner of the house and can be activated or deactivated by him only.
- Always change the default factory password in the applicable models immediately after the installation is complete.
- Inserting batteries in the wrong direction or wrong polarity in the battery compartment may lead to Fluid tears or ruptures, so always make sure you insert the batteries as per the correct polarity, which matches the product's polarity (+/-).
- Always keep the Master Passcode safe, and in the case of forgotten Master Passcode, please get in touch with our helpline number for further assistance.
- Always use a soft and dry cloth to clean the product.
- Replace all old batteries with a new ones when changing batteries. Using old batteries in combination with the new ones can cause the product to malfunction.
- Use Alkaline batteries only.
- Using rechargeable batteries may cause product malfunction.

Don't's

- Do not Dismantle the product by yourself. Always take the help of the certified service technician for dismantling the product as improper handling may cause damage to the product resulting in malfunctioning of it.
- Do not insert batteries with reversed polarities. Always check and ensure proper polarity of batteries in line with Product Polarity while inserting it into the product as any mismatch can result in liquid leakage or rupture.
- Do not install, disassemble or repair the product without the help of a certified service technician.
- Do not give excessive impact force on the product.
- Do not directly spray water when cleaning the product. Water coming through into the product causes malfunction or abnormal operation.
- Do not install the product in an area exposed to the external environment.
- Do not let dew condensation enter the product as it may cause product malfunction if a certain level of moisture enters into it, so make sure to remove any source of dew condensation through periodic ventilation or paper weather stripping.

User Instruction

- Please read all the safety & operating instructions before the product installation.
- To ensure continuous access security, change your PIN code regularly.
- Only use new batteries & beware of potential battery leakage, which may cause damage/malfunction to the product.
- Replace all batteries when prompted by the automatic low battery indication and do not re-use any of the batteries.
- Installation must be done by an Ozone service professional.
- Disassembly or attempted repair, rework or reverse engineering is prohibited without written consent & approval of Ozone except for the normal installation of the product by a designated service professional.
- Clean the product only with a dry microfiber cloth.
- Do not insert or press any of the buttons with Pin or sharp objects.
- This product has not been tested for external use. Avoid any contact with water.
- This product was designed for use in weather-protected outdoor and indoor areas and domestic application only.
- Do not expose the product to strong shocks or vibration.
- Keep the filled-out warranty certificate and invoice, as it is required for processing all warranty requests.
- The information in this user guide is subject to change without notice.

This product must be installed by an Ozone professional. In case of defects resulting from installation by other than an Ozone professional, the Product warranty will be void. Ozone reserves the right to charge on out-of-warranty products.

1.1 LOCK STRUCTURE

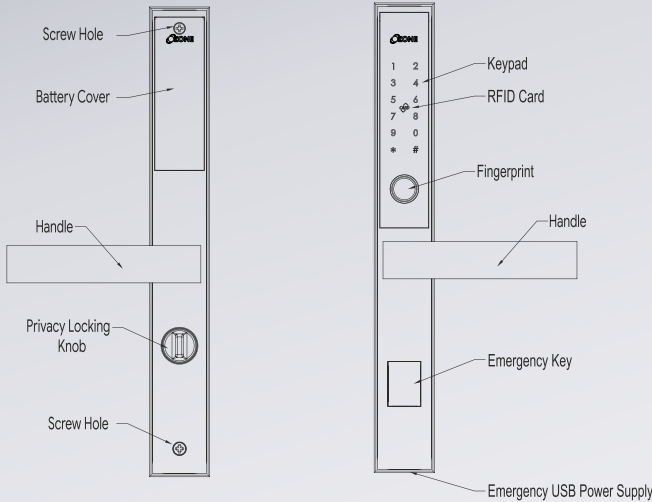

PRODUCT FEATURES

- 1) MicroUSB emergency power supply: In case of emergency the product could be operated by USB through power bank.
- 2) Emergency Key Unlock: Use emergency key to unlock the door when battery is completely drained or in any emergency situation.
- 3) Fingerprint : use registered fingerprint to open the lock.
- 4) Digital keypad / RFID card induction area: use registered password or RFID card to open the lock.
- 5) Battery cover: open battery cover to change the battery.
- 6) Reset button: Use reset button for factory setting or initialization setting.
- 7) Privacy locking Knob: While enable privacy locking no one can open the lock from outside except emergency key.
- 8) Smart Freeze & Auto Secure: More than 5 times wrong password in 5 minutes, the keypad will be locked for 90sec., the lock will not respond to any operation within the 90 seconds,
- 9) Anti-theft password: Enter the password as follows when opening the door: XXX password XXX. you can add some irrelevant digits before and after the password, and then press # to confirm. The actual password must be included.

Technical Specification

Lock Material	Zinc Alloy, ABS
Color	Black
Door Thickness	35-80mm
Communication	OzoLife
Support OS	iOS 7.0 or above, Android 4.4 or above
Battery Life	(6-8 months) by 15 times normal unlock
Power Supply	DC6V:4pcs AAA alkaline batteries
Static Current	≤50 uA
Dynamic Current	<200 mA
Unlock Way	Fingerprint, RFID Card, Password, OzoLife App, Emergency Key
Unlock Time	1-1.5 Seconds
Working Temperature	-20° - 50°
Working Humidity	10% - 95%
Factory Passcode	Factory Master Password : 123456 afer configuration, it will be valid
Mortise Type	28*85mm
Virtual Password	Available
Administrator capacity	9
User Capacity	FP+PWD+ RFID card (300)
Door Application	Wooden/ Metal Door

Installation Steps

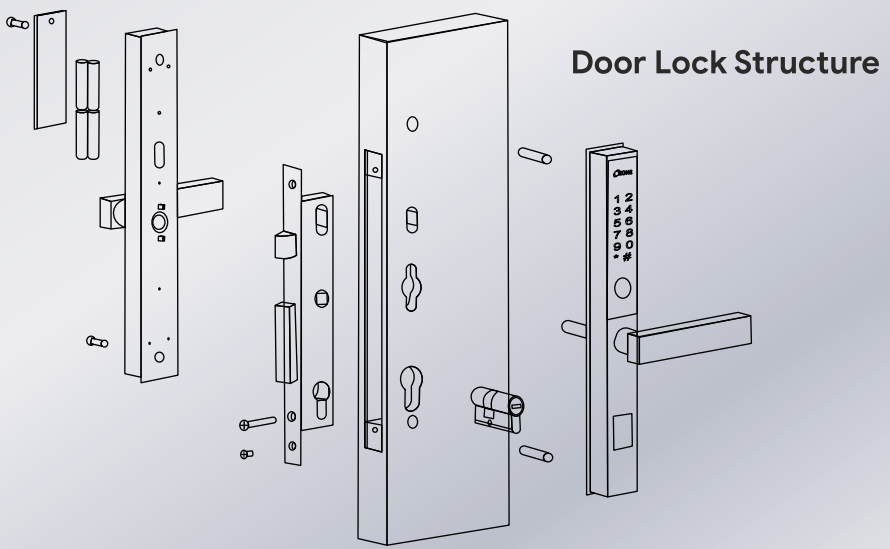
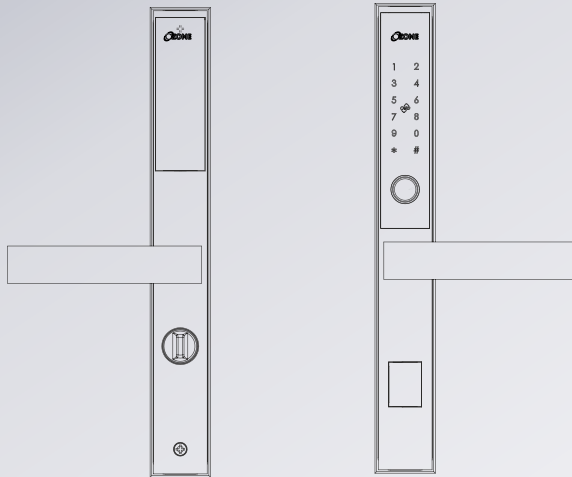

Installation Steps

Install the Lock Body and Lock Cylinder

3

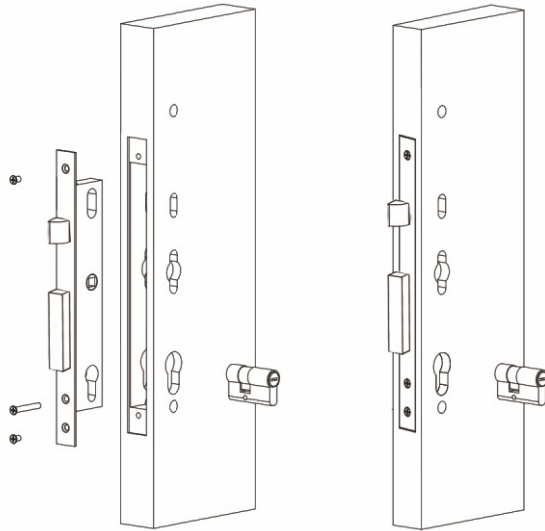

Install the Front Panel

4

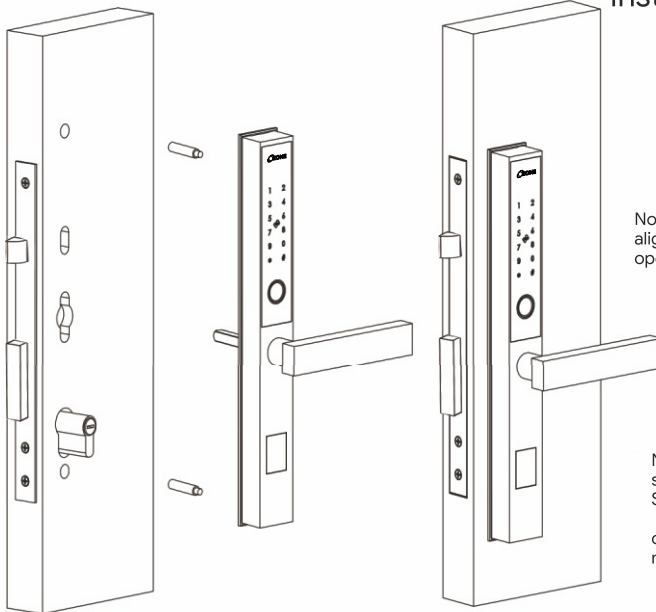

Note: The arrow mark must be aligned with the right or left open direction arrow marks.

Note: Firstly, install the mating screw tube on the front panel. Second, install the front panel to the door (Connect the wire correctly. Do not misplace the matching holes)

Installation Steps

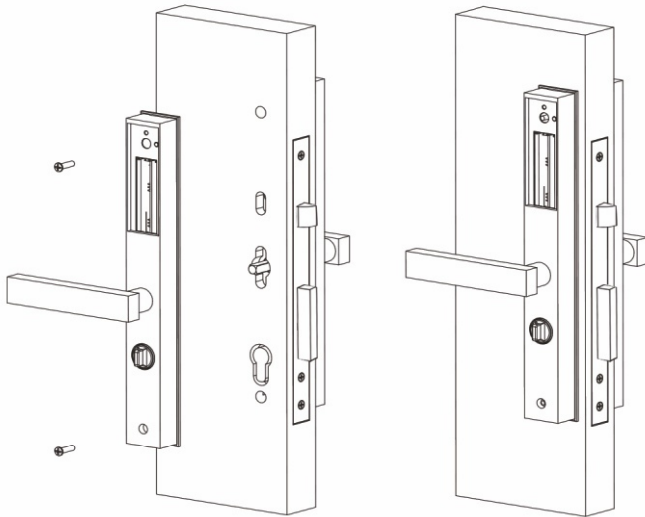

Install the Back Panel

5

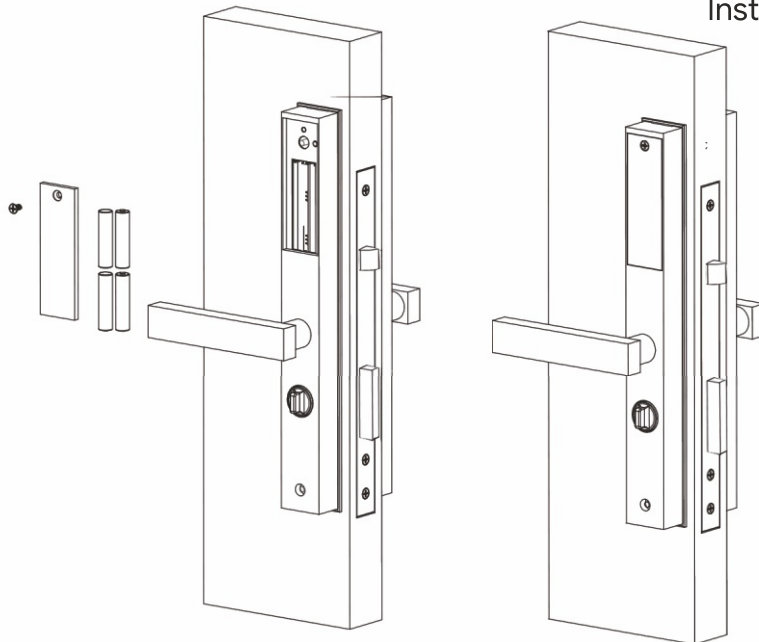

Install the Batteries

6

Installation Steps

Installation is complete,
test the door lock

7

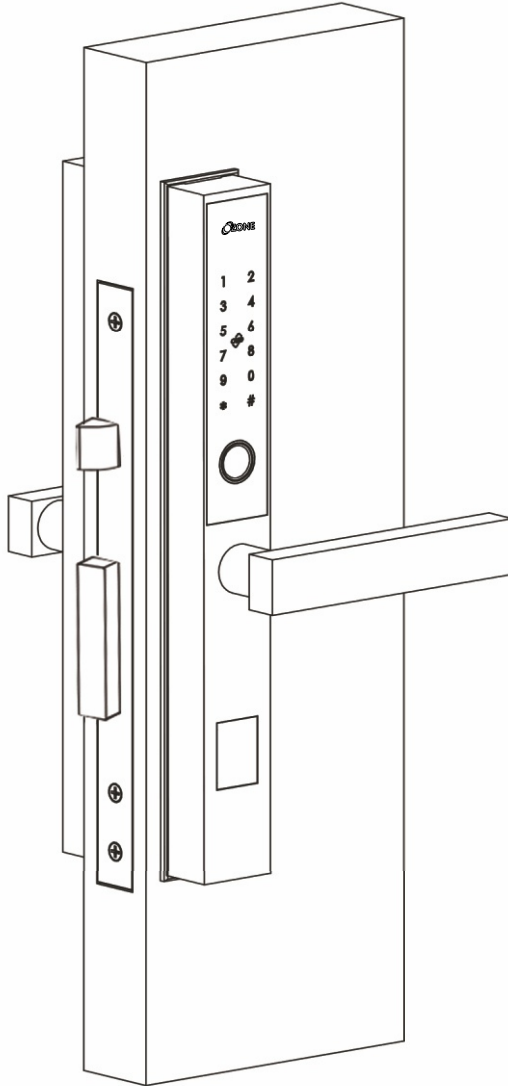

Operations Steps

1. Reset

Press the reset key (on the back panel) for 5 seconds, then voice navigation "initialization succeeded".

Note: The initial password is "123456", or any Fingerprint can open the door. After setting the administrator information, the initial password will be deleted automatically.

2. Add Administrators Information (up to nine Administrators)

The "#" key is the Confirm Key or the Menu Function Key.

The "*" key is the Clear Key/Back Key.

In the initial state, touch the screen, press "*" and then press "#" buttons, or directly press the "Set" button on the back panel, then add the administrator information.

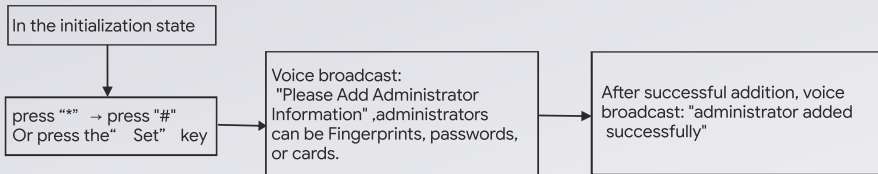

Note: Before adding the administrator information, you can use the initialized password (123456) to open the door.

After adding the admin information, the initial password will be automatically invalid.

3. Add Unlocking Information

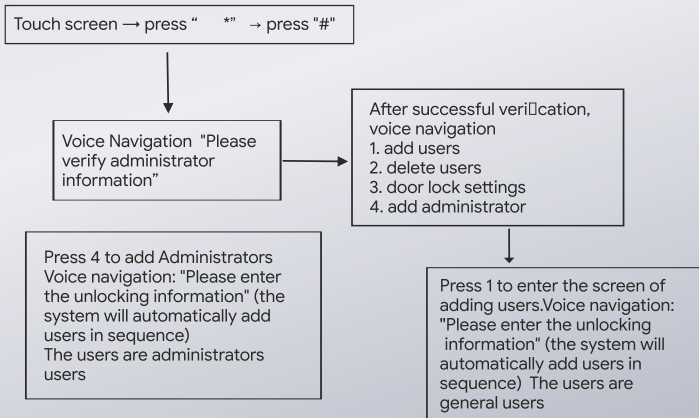

During the adding process, you can not add information that already exists
Password: 6 to 12 digits

Note:

The administrator user is recommended to set at least one group of fingerprint/password/card, and be sure to remember the administrator user information

Operations Steps

Setup steps

4. Delete Unlocking Information

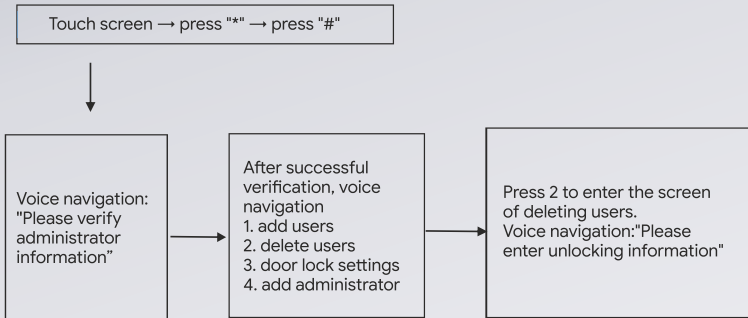

Note: To delete the user, fingerprint/card user must verify the unlocking information.

5. Passage Mode

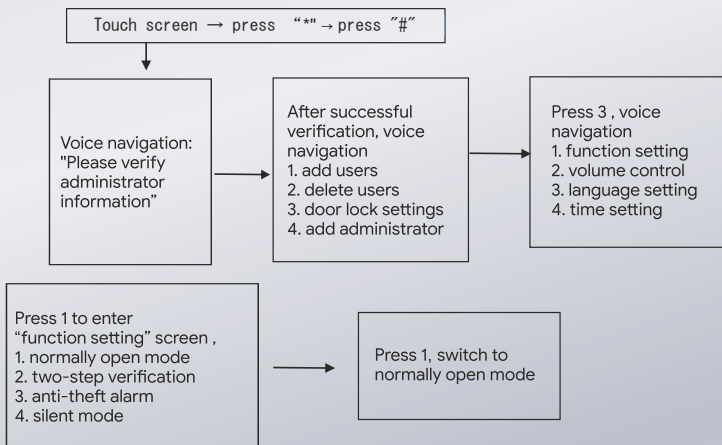

Note: After the normally open mode is turned on, each time when unlocking, the lock will enter the normally open state, press "#" to lock.

Operations Steps

6.Silent Mode (Volume Control)

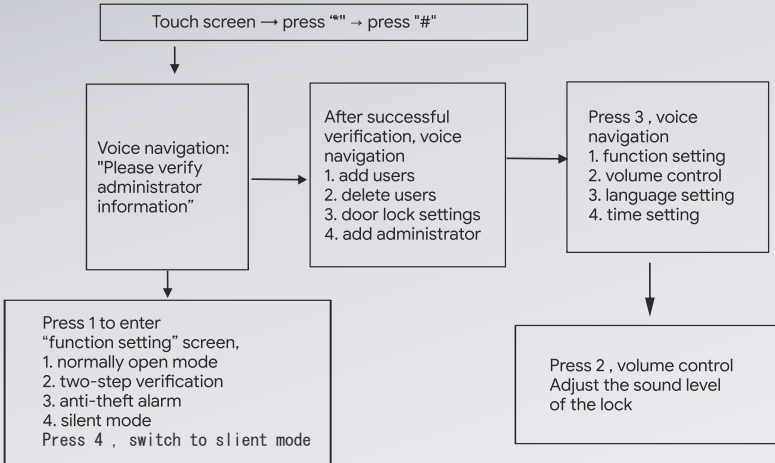

Note: After the mute mode is turned on, every time unlock will be mute.

7.Dual Combination Mode

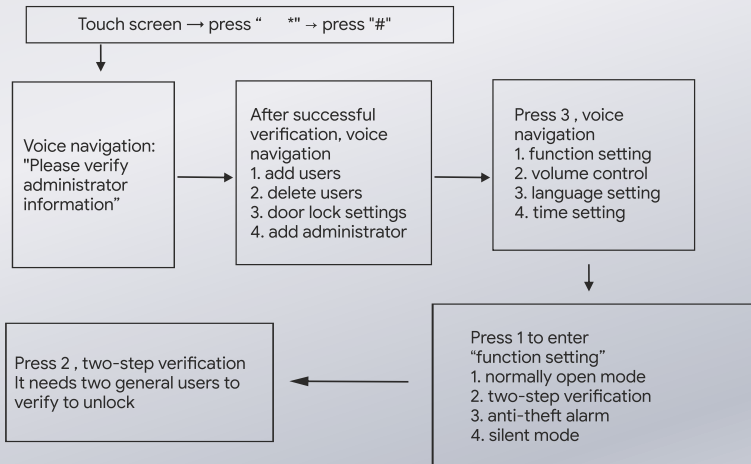

Note: Two-step verification is only for general users, and administrators are not restricted.

Operations Steps

8. Language Setting

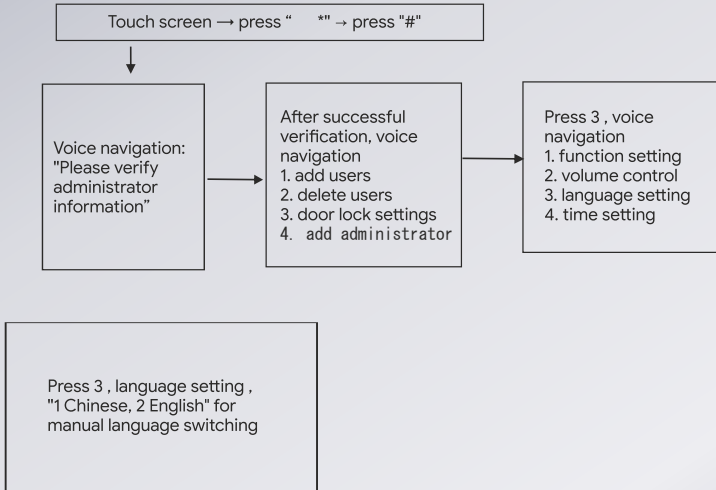

Note: When restoring the factory default settings, the original language remains unchanged, you need to enter the setting interface to switch language

9. Time Setting

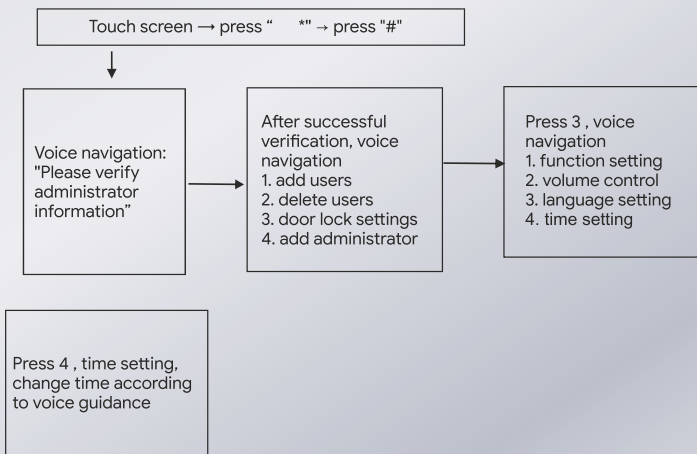

Operations Steps

- 1 Search OzoLife app from the App store and register Press *# after add admin than Then press 1 form add user.
Open OzoLife App and access it and follow below way to add lock (Auto connection/add manually)

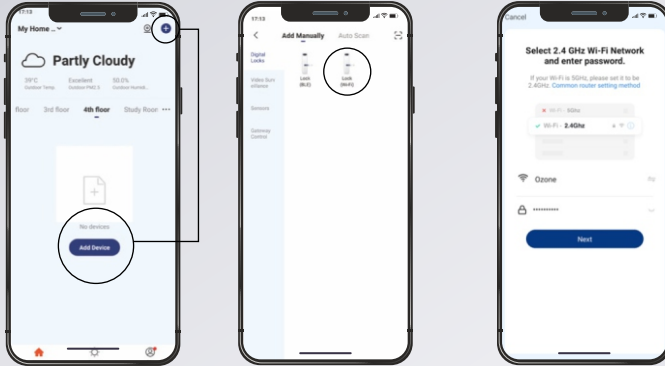

TEMPORARY CODE SETTING

- 1 After adding temporary code, need to try on lock then finished.
- 2 Max. Support 10 groups of code, and code can be edited or deleted.
- 3 Temporary codes can be set by period.

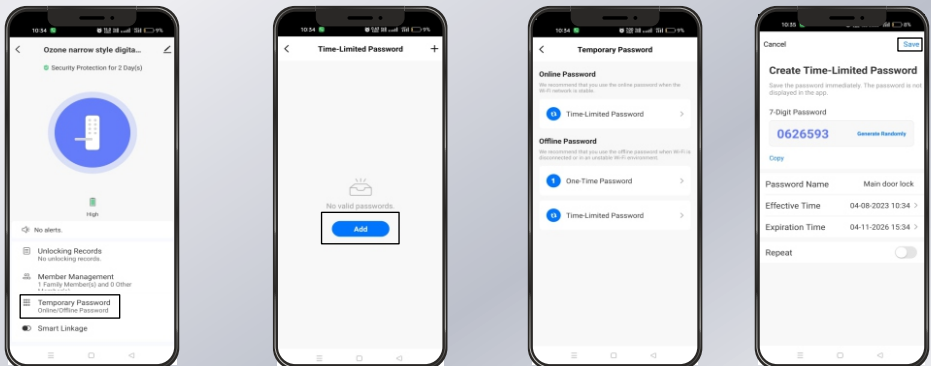

4 Temporary offline password: Create the Temporary offline password as per below.

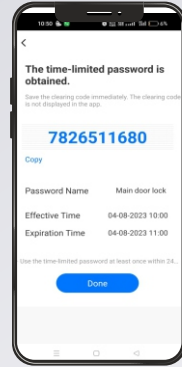
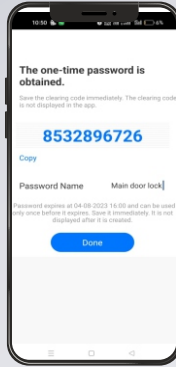
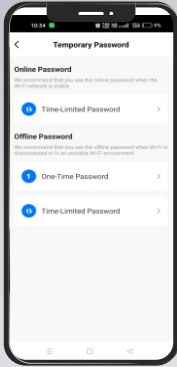

5 Remote unlocking: Press 9 and “#” button. Unlock request will come on OzoLife app then unlock the door.

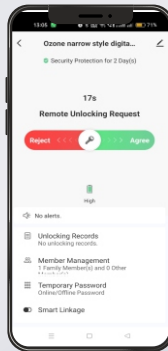

10. Packing Details

Name	QTY	Name	QTY
Front Panel	1pc	Rear Panel	1Set
Gasket Rub ber Plate	2pcs	Emergency Key	2Pcs
M4X45 screws	2pcs	User manual	1Pc
Cut out template	1pc	Mortise	1Pc
Spindle	1pc	Strike Plate & box	1Pc
4X20 screws	6pcs	Screw Ø6x35	3Pcs
RFID Card	2pcs	Battery Optional	4AAA Pcs
M4x35 screws	2pcs	Plate Case	1Pc

FAQs

- 1** How to read operation records?
Select “Opening record” option on lock main interface

- 2** After installation, touch sensing keyboard or screen not responding.

 - a) First check that the positive and negative electrodes of the battery have been installed upside down.
 - b) Check whether the battery has enough power.
 - c) Remove the back panel body and see if it's connected with the front panel.
 - d) Remove the lock and check whether the connecting wires of lock body are not squeezed or twisted.

- 3** Unable to register Fingerprint.

 - a) Check the Fingers for dirt or wear. Also check the Fingerprint sensor on the lock for dirt and oil stains, etc.
 - b) Check if the Fingerprint sensor is working properly (Press any Fingerprint on sensor to see if there is any response).

- 4** Why is the smart lock consuming power faster than usual?

 - a) Large standby power consumption.
 - b) Short circuit.

- 5** After how many incorrect password attempts will the lock go in auto secure mode?
For how long it will be in auto secure mode?
Every time you enter a wrong password more than 5 times in a row, the keyboard is locked for 90 seconds.

WARRANTY CARD



CUSTOMER DETAIL			
Name		Address	
Mobile No.			
E-Mail ID			
City		Landmark	
State		Pin Code	

PRODUCT PURCHASE DETAIL			
Digital Door Lock		Dealer Name & Address	
Model No.			
Online / Offline		Installation Address	
Serial No.			
		Invoice No.	
		Total Quantity	

Special Instructions: _____

- Please replace the battery as soon as the low voltage alarm signals it.
- Read this manual carefully before installation and keep it safe, for future reference.



OzoLife



Scan QR
Code to
access
website